

CliniMix[®] CP-BS Inwall Thermostatic Progressive Shower Mixer with GalvinCare[®] Handle H&C

PRODUCT CODE:

- WM-TMVPMSCS1



WaterMark
AS 4032.4 Lic. WMKA21989
SAI Global

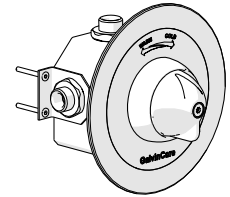

TABLE OF CONTENTS

1.0	INTRODUCTION	1
2.0	TECHNICAL DATA	2
3.0	SAFETY	2
4.0	DESCRIPTION	2
5.0	DIMENSIONS	2
6.0	WATER SUPPLY CONDITIONS	3
7.0	INSTALLATION	3
8.0	OPERATION AND TESTING	5
9.0	COMMISSIONING	6
10.0	ISOLATE INLETS AND CLEAN FILTERS	7
11.0	ADJUSTMENT OF THE MIX TEMPERATURE	8
12.0	REMOVING AND INSPECTING MIXER CARTRIDGE	9
13.0	MAINTENANCE	10
14.0	DISINFECTION	10
15.0	TROUBLESHOOTING	11
16.0	WARRANTY	12

1.0 INTRODUCTION

The CliniMix[®] CP-BS Inwall Thermostatic Progressive Shower Mixer with GalvinCare[®] Handle is a high-performance thermostatic mixing valve suitable for a wide range of applications. The mixing valve has the following features:

- This progressive shower mixer provides state of the art features to comply with healthcare requirements.
- The GalvinCare[®] paddle handle provides straight forward temperature control and minimises ligature risk.
- Suitable for high and low pressure systems with a thermostatically controlled water temperature of 48°C maximum.
- Enables water to be mixed closer to the point of discharge, minimising stagnant warm water which provides ideal conditions for legionella bacteria to grow.
- Smooth internal components and body reduces scale build-up and bacteria growth.
- Maximum temperature limiter fitted for protection from accidental scalding.
- Clean smooth lines facilitate fast and easy cleaning.
- All servicing and commissioning can be done without removing the device. Easy access isolators, help minimise time spent on commissioning and maintenance.
- Designed to provide stable mixed temperature with rapid shut down in the event of cold or hot water supply failure.
- Approved to: AS/NZS 4032.4.

IMPORTANT: All GalvinCare[®] mental health taps are tested in accordance with AS/NZS 3718 and leave our premises in good working order. Document to be read in conjunction with CliniMix[®] Progressive Thermostatic Mixing Valve manual.

2.0 TECHNICAL DATA

Inlet	1/2" BSP – Male	
Outlet	1/2" BSP – Male	
Headwork	Thermostatic mixing valve	
Working Pressure Range (kPa)	Min	20
	Max	500
Working Temperature Range (°C)	Min	5
	Max	85
Finish	Chrome	
Wall Recess required (mm)	Ø149 x 6	

NOTE: Galvin Specialised continually strive to improve their products. Specifications may change without notice.

3.0 SAFETY

The CliniMix® Inwall Thermostatic Progressive Shower Mixer with GalvinCare® Handle is a high-performance valve designed to give stable and dependable operation, provided it is installed, commissioned, operated and maintained as per the recommendations outlined in this manual. It should be noted however that this valve should not be considered as an alternative to adequate supervision and duty of care during its use and operation.

4.0 DESCRIPTION

This manual covers the CliniMix® Inwall Thermostatic Progressive Shower Mixer with GalvinCare® Handle. This product is designed to provide water from ambient cold up to a safe maximum temperature for showering. This mixing valve is supplied with integral isolating valves, strainers, check valves, flow regulators located in-body and a facility for thermal disinfection of the cold inlet side and mixed water outlet.

5.0 DIMENSIONS

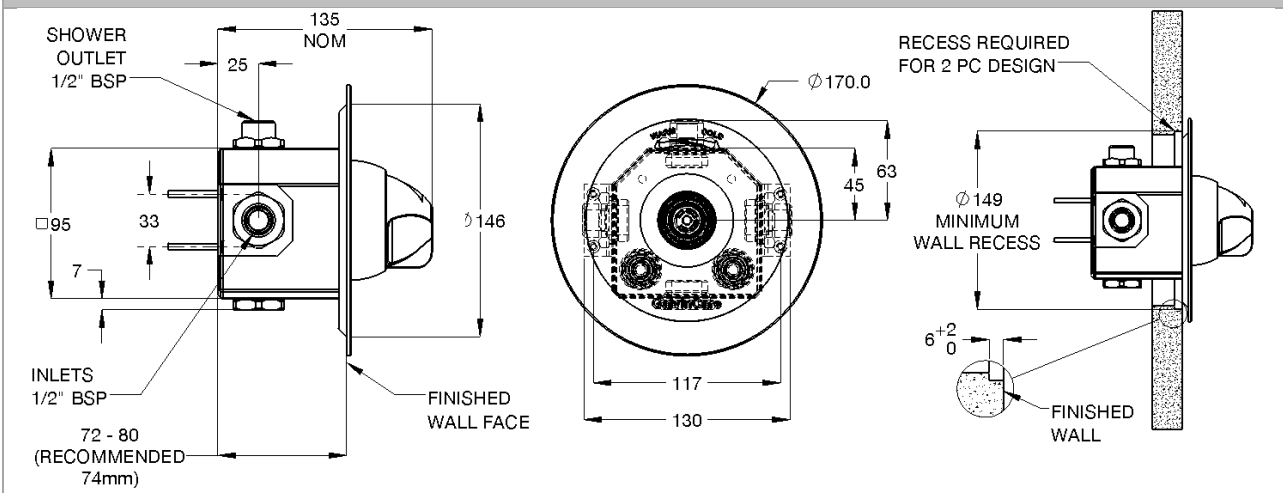

6.0 WATER SUPPLY CONDITIONS

INTRODUCTION

This CliniMix® CP-BS Inwall Thermostatic Progressive Shower Mixer with GalvinCare® Handle is manufactured to the highest standards. When installed the supply conditions detailed below must be observed.

SUPPLY REQUIREMENTS

This mixer is designed to be installed on all types of plumbing systems.

Hot and cold water supply pressures should be reasonably balanced; however, the mixer will function within specification on unequal pressures up to 10:1.

The mixer has integral isolating valves which permit servicing of the strainer, check valve/flow regulator and thermostatic cartridge. They are also used for thermal disinfection.

The minimum pressure for the correct thermal operation is 20kPa. However, to achieve an acceptable flow performance at very low pressures it may be necessary to remove the combined check valve and flow regulators and replace them with simple check valves.

Hot Temperature Supply Range (°C)	Min	5
	Max	85
Minimum Temperature Differential (between the supply and the outlet temperature) (°C)		10
Adjustable Temperature Range	Min	35
	Max	48
Maximum Static Pressure (kPa)		1000
Working Pressure Range (kPa)	Min	20
	Max	500*
Maximum Outlet Pressure (kPa)		500
Permitted Supply Pressure Variation		10:1
Factory Set Thermostatic Temp. (°C)		41
Maximum Thermostatic Temperature (°C)		48
Minimum Flow Rate for Stable Outlet Temperature (LPM)		6
Maximum Flow Rate (LPM@300kPa)		18

*Tapware must be installed in accordance with the provisions of AS/NZS 3500. Installations not complying with AS/NZS 3500 may void the product and performance warranty provisions.

7.0 INSTALLATION

The CliniMix® Thermostatic Progressive Mixing Valves must be installed using the appropriate Standard, Code of Practice and legislation applicable to point of install.

The CliniMix® Thermostatic Progressive Mixing Valves must be installed by a licensed plumber.

If the valve is not installed correctly then it will not function correctly and may put the user in danger. It may also void the warranty of the valve.

Prior to the installation of the valve, the system must be checked to ensure that the system operating conditions fall within the recommended operating range of the CliniMix® Thermostatic Progressive Mixing Valve. If the hot water supply temperature is greater than 90° Celsius, the valve may be damaged. If the temperature of the hot water will rise above 90° Celsius a suitable temperature limiting valve must be fitted to the hot water supply, prior to the inlet fittings. This temperature limiting valve must be installed as per the manufacturer's instructions. It is important that both inlet dynamic supply pressures are 500kPa or less. If either supply pressure exceeds 500kPa then a suitable pressure reducing valve must be fitted prior to the inlet control valve to reduce the pressure to an acceptable limit.

These pressure reducing valves must be installed as per the manufacturer's instructions. To achieve optimum performance from the valve it is recommended that the inlet pressures are balanced to within 10% of each other.

To ensure that the mixing valve operates correctly, it is necessary that the pipe-work is thoroughly flushed with clean water before the valve is installed. This will remove any physical contaminants from the pipe-

work, ensuring trouble-free operation. During the flushing procedure, care should be taken to prevent water damage occurring to the surrounding area.

The valve should be installed so it can be easily accessed for maintenance or servicing.

During installation or servicing, heat must not be applied near the mixing valve or inlet fittings, as this will damage the valve and inlet fittings internals. Failure to comply with this requirement will damage the valve and fittings. It will put the user at risk and it will void the warranty of the valve.

Note: To effectively control microbial hazards during system design, installation, commissioning and maintenance, the requirements of local legislation shall be adhered to.

Note: In some installations, certain types of tapware devices such as flick mixers and solenoid valves are used. The water pressure may be seen to spike outside that recommended for the valve, during rapid shut off conditions with these types of devices. Even if the spike only lasts a split second it is still considered to be outside the operating conditions and may cause the valve to operate incorrectly. In the event that this does occur, measures must be taken to control the spike, such as the installation of an inline pressure reducing valve directly before the valve inlets.

7.1 INSTALLATION

IMPORTANT: Galvin Engineering products must be installed in accordance with these installation instructions and in accordance with AS/NZS 3500, the PCA and your local regulatory requirements. Water and/or electrical supply conditions must also comply to the applicable national and/or state standards. Failing to comply with these provisions shall void the product warranty and may affect the performance of the product.

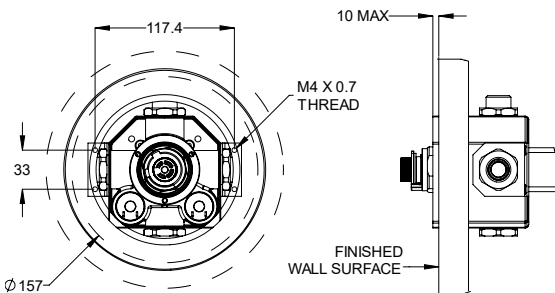

1. Mounting

- Ensure the rough in details have been followed to allow correct fitment of the Progressive Shower unit. The unit must be mounted so that the inlets are horizontal, and the outer plastic box on the Progressive shower is set to be flush with or proud of the finished wall (to a maximum of 10mm).

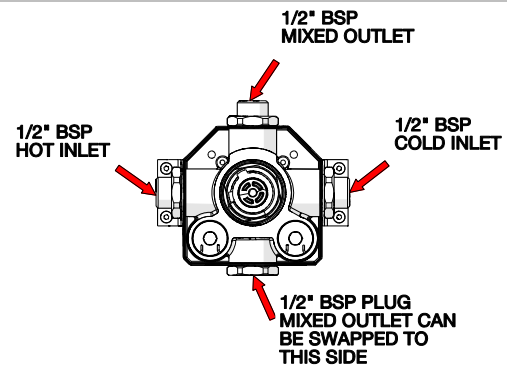

2. Connect Water Supply

- Fit hot and cold water supplies to the correct side of the shower unit and the outlet to the shower head. To make this easier the outlet can be changed from one end to the other by swapping it with the opposite plug. Do not use heat on any of these connections as it will damage the shower.

Note: Hot and cold inlet cannot be swapped.

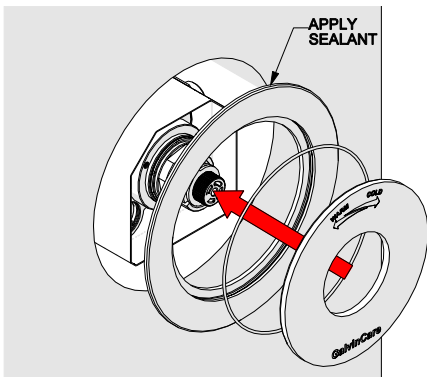

3. Seal outer faceplate and fit inner faceplate

- Seal the outer faceplate to the wall using a suitable sealant.
- Insert the inner faceplate followed by the shower flange, ensuring the provided o-rings are in place

Note: Cartridge spline must be parallel with the faceplate within 1°.

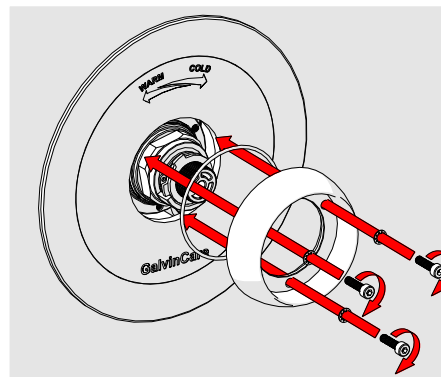

4. Secure flange

- Secure the flange with the three supplied screws.
- Use supplied M4x20mm screws, if not suitable change to M4x16mm screws.
- Wipe off excess sealant on the outer faceplate when secured to the wall.

Note: Before tightening the flange make sure the handle fits correctly. Put screws into flange and tighten finger tight, the flange should still be able to move. Slide the handle onto spline and move the flange until central to the handle. Remove handle and tighten the screws (it is best to tighten the screws in sequence a little at a time to avoid the flange moving). Refit handle.

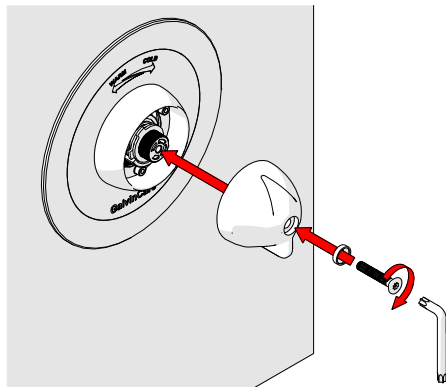

5. Fit handle

- Secure the handle with supplied tamper proof screw. Ensure the handle is oriented correctly.

8.0 OPERATION AND TESTING

After installation, check for leaks and correct operation.

As the handle is rotated anti-clockwise the delivered water progresses from cold through warm to the pre-set maximum temperature of approximately 41°C.

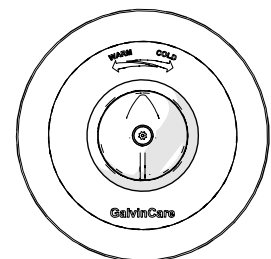

9.0 COMMISSIONING

Initial Test for Correct Operation

The following must be checked to ensure the correct performance of the progressive thermostatic mixer:

- the supply pressures and temperatures are within the range of operating pressures and temperatures for the thermostatic valve.
- the supply temperatures are within the range permitted for the unit.

Please record the testing done during the commissioning and record the temperature of the hot and cold-water supplies and the temperature of the mixed water at the full hot setting.

A calibrated digital thermometer having rapid response time with maximum temperature hold will be required to check and set the outlet mixed temperature of the mixer.

To Commission

To test the temperature, open the valve and allow the mixed heated water to flow for at least 30 to 60 seconds so the temperature can stabilise before taking a temperature reading at the outlet with a digital thermometer. The flow rate should be at least 4L/min.

The temperature should be taken close to the mixer's outlet and if the outlet temperature requires adjustment then follow the temperature adjustment in the installation instructions.

Shut Down Test

Once the correct outlet temperature has been achieved, the valve's internal mechanism should be exercised at least 3 times by alternately shutting off the hot and cold supplies while the mixer is set in the full hot position.

Shut Down Test 1

With the mixer still set in the full hot position (handle fully turned anti-clockwise) and with both supplies turned on, allow the mixed water temperature to stabilise for at least 15 seconds and note the outlet temperature. While holding a digital thermometer in the outlet flow, quickly isolate the cold water supply to the valve

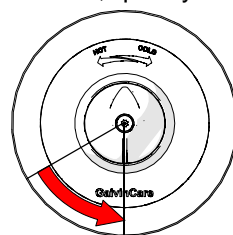

Handle to hot position

The outlet flow should quickly reduce to be less than 0.1L/min following the isolation. Recording of the temperature should continue after isolation and should not exceed the maximum temperature set out in the applicable standard or code of practice for each state.

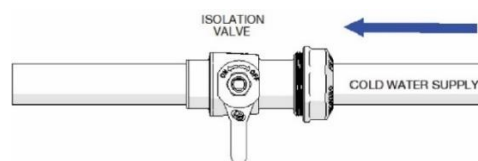

Restore the cold-water supply to the valve. After the mixed water temperature has stabilised note the outlet temperature ensuring the outlet temperature has re-established. The time taken to stabilise the temperature should not exceed the maximum time set out in the applicable standard or code of practice for each state.

Shut Down Test 2

With the mixer still set in full hot position and with both supplies turned on allow the flow to stabilise for at least 15 seconds and record the temperature. Quickly isolate the hot water supply to the valve.

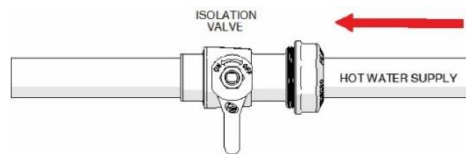

The outlet flow should quickly reduce to be less than 0.4L/min following the isolation. The volume of mixed water discharged for a period of between 5-35 seconds should be measured and should not exceed the maximum volume set out in the applicable standard or code of practice for each state.

Restore the hot water supply to the valve and measure and record the outlet temperature after the mixed water temperature has stabilised. The time taken to stabilise the temperature should not exceed the maximum time set out in the applicable standard or code of practice for each state.

Ensure that all details of the Commissioning Report are completed, and a copy is kept with the installer and owner of the premises.

The valve is now commissioned, and it can be used within the technical limits of operation.

10.0 ISOLATE INLETS AND CLEAN FILTERS

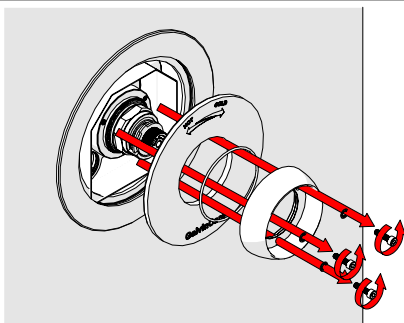

1. To isolate the shower, remove the handle and flange by unscrewing and carefully remove the inner faceplate and flange o-ring. (As shown)

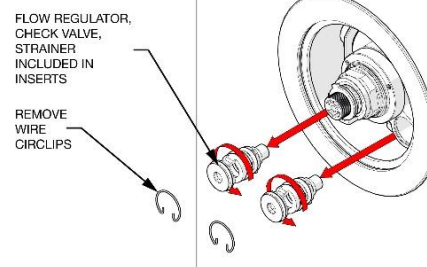

2. It is recommended the shower is isolated at supply
3. Remove the two wire clips and unscrew the two assemblies. As they are removed the water supply to the valve will be isolated.
4. The strainers and check valves can now be examined and cleaned or replaced as necessary.
5. Re-assemble the strainer, check valves and re-fit the wire clips.
6. Turn on water supply.

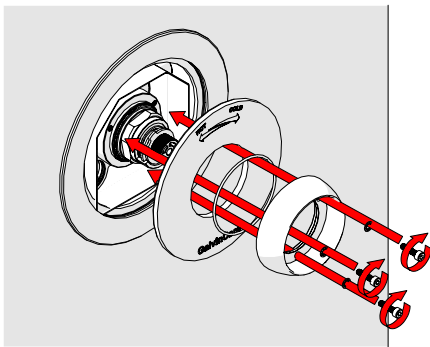

7. Fit the inner faceplate into the outer faceplate. Ensure the marking on the top of the plate is positioned correctly.

Note: Before tightening the flange make sure the handle fits correctly. Put screws into flange and tighten finger tight, the flange should still be able to move. Slide the handle onto spline and move the flange until central to the handle. Remove handle and tighten the screws (it is best to tighten the screws in sequence a little at a time to avoid the flange moving). Refit handle.

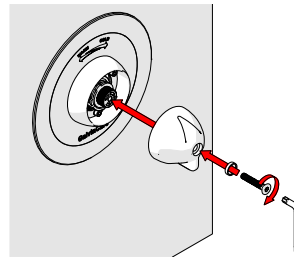

8. Fit the handle and fasten so the arrow shape on top of the handle matches the marking on the faceplate.

11.0 ADJUSTMENT OF THE MIX TEMPERATURE

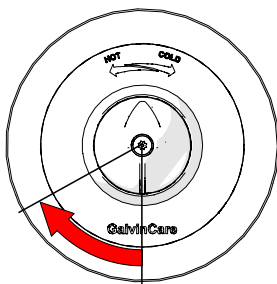

1. Set the handle to cold position.

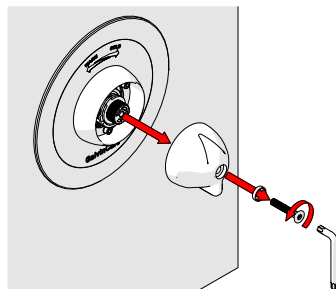

2. Unscrew the tamper proof screw from handle. Pull out handle assembly from the body

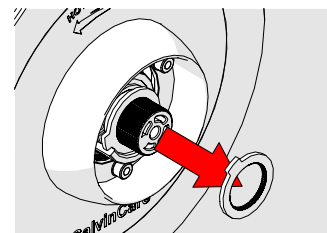

3. Remove the upper brass ring. Make sure the control rod doesn't rotate during the next steps.

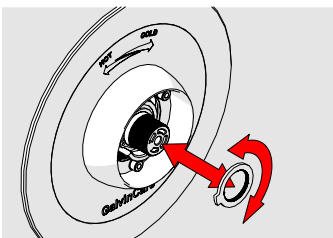

4. Remove the lower brass ring (temperature setting ring) and rotate the brass ring clockwise to increase temperature or anti-clockwise to decrease. Refit to spline in new position.

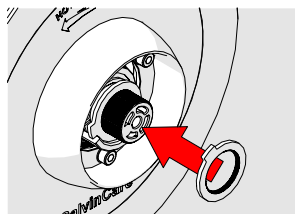

5. Reposition the upper ring in the same position against step.

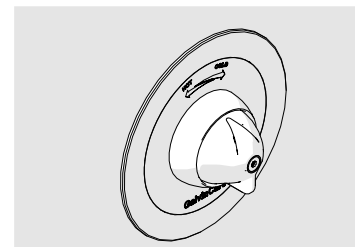

6. Once set, reverse step 2 to reassemble.
7. Re-test temperature to ensure correct operation.

12.0 REMOVING AND INSPECTING MIXER CARTRIDGE

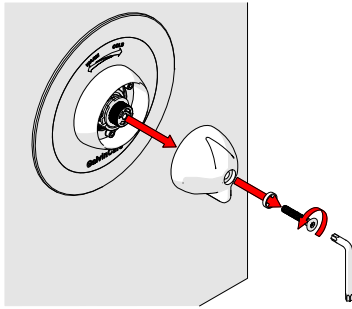

1. Remove handle assembly

- Unscrew the tamper proof screw from handle. Pull out handle assembly from the body

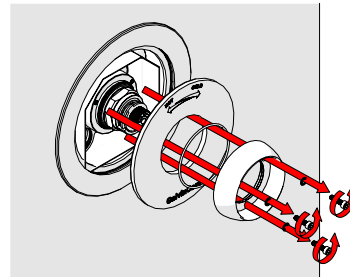

2. Remove flange and faceplate

- Unscrew the three screws and pull out the flange and faceplate from unit. **Do not remove the outer faceplate.**

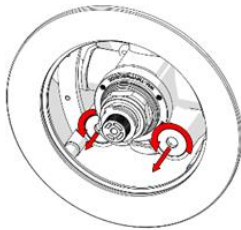

3. Isolate the shower

- It is recommended the shower is isolated at supply.
- To isolate the shower loosen the isolators in an anti-clockwise direction until they are touching the circlips. This closes the shut off valves.
- Open the valve and check if there is a flow.

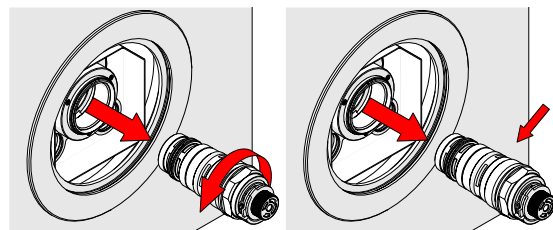

4. Remove cartridge nut and check cartridge

- Unscrew cartridge and remove from body. Check the cartridge for wear and damage. Replace if required (replacement cartridge available through your supplier).
- Check and clean the body of all debris.

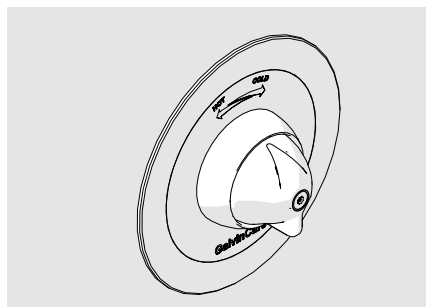

5. Re-assemble

- Re-assemble, by reversing steps 4 to 1.
- To re-open the shut off valves tighten the flow regulator/check valve/filter units until tightened (do not over tighten) and refit the two clips.
- Check for leaks and correct operation.

Note: Before tightening the flange make sure the handle fits correctly. Fit screws into flange and finger tighten. The flange should still be able to move. Slide the handle onto spline and move the flange until central to the handle. Remove handle and tighten the screws (it is best to tighten the screws in sequence a little at a time to avoid the flange moving). Refit handle.

13.0 MAINTENANCE

Thermostatic Mixing Valves are precision products and as such any maintenance needs to be undertaken in a clean environment and in accordance with the manufacturer's instructions.

The purpose of servicing regularly is to monitor any changes in performance due to changes in either the system or the product. This may highlight the need to adjust either the supply system or the product. These products should be checked at 6 to 8 weeks and again at 12 to 15 weeks after commissioning. The results are to be compared against original commissioning settings.

If there are no significant changes at the mixed temperature outlet then a 6 monthly servicing cycle may be adopted. Otherwise, servicing checks should be carried out more frequently (e.g. every 4 months).

Follow the recommended maintenance procedures detailed in this section.

During servicing, note the following:

1. Repeat the procedure of recording and checking supply temperatures. (The same type of measuring equipment should be used)
2. If the temperature has changed significantly from the previously recorded values, the following should be checked:
 - a. All integral valve filters are clear of obstruction.
 - b. All integral check valves are clean and working properly to prevent backflow.
 - c. Any isolating valves are fully open.
 - d. The thermostat is free of debris.

When satisfied with the mixed outlet temperatures re-record the temperatures.

14.0 DISINFECTION

A disinfection kit is available. For more information please visit www.galvinengineering.com.au.

15.0 TROUBLESHOOTING		
PROBLEM	CAUSE	RECTIFICATION
The desired mixed water temperature cannot be obtained, or valve is difficult to set.	<ul style="list-style-type: none"> - Hot and cold supplies are fitted to the wrong connections. - Thermostatic cartridge contains debris or is damaged. - Strainers contain debris. - Non-return devices are damaged. 	<ul style="list-style-type: none"> - Refit the valve with hot/cold supplies fitted to the correct connections. - Clean cartridge ensuring all debris is removed and components are not damaged. Replace if necessary. - Clean strainers of debris. - Check non-return device is not jammed. - Check for airlocks in the water supply.
Handle rubs against the flange	<ul style="list-style-type: none"> - The faceplate is not perpendicular to cartridge spline within 1°. 	<ul style="list-style-type: none"> - Remove and re-mount properly ensuring faceplate is within 1° perpendicular to cartridge spline.
The water temperature selected is cold yet hot water comes out.	<ul style="list-style-type: none"> - Hot and cold water supply connections are installed in reverse. 	<ul style="list-style-type: none"> - Refit the valve ensuring the hot/cold supplies are fitted to the correct connections.
The thermostatic mixing valve will not shut down.	<ul style="list-style-type: none"> - The hot to mix temperature differential is not 10°C or greater. - Thermostatic cartridge contains debris or is damaged. - Non-return devices are damaged. 	<ul style="list-style-type: none"> - Raise hot water temperature. - Clean the cartridge ensuring that all debris is removed.
Mix temperature unstable.	<ul style="list-style-type: none"> - Flow rate below 2L/min. - Thermostatic cartridge contains debris or is damaged. - Strainers contain debris. - Non-return devices are damaged. 	<ul style="list-style-type: none"> - Rectify any pressure deterioration. - Clean the cartridge ensuring that all debris is removed and components are not damaged. Replace if needed. - Clean strainers ensuring debris is removed. - Check non-return device is not jammed.
Mix temperature changing over time	<ul style="list-style-type: none"> - Inlet conditions (pressure or temperatures) are fluctuating. - Strainers contain debris 	<ul style="list-style-type: none"> - Install suitable pressure control valves to stabilise inlet conditions. - Clean strainers ensuring debris is removed.
Either full hot or cold flowing from outlet fixture	<ul style="list-style-type: none"> - Upper temperature ring is not correctly set. - No flow from hot and cold supplies. - Damaged check valves. 	<ul style="list-style-type: none"> - Re-set temperature to between 35-46°C as required. - Check water is switched on. - Replace faulty check valves.
Water is not flowing from outlet.	<ul style="list-style-type: none"> - Hot or cold water failure. - Thermostatic cartridge contains debris or damage - Strainers contain debris. 	<ul style="list-style-type: none"> - Restore inlet supplies and check mix temperature. - Clean the cartridge ensuring that all debris is removed and components are not damaged. Replace if needed. - Clean strainers.

16.0 WARRANTY

The Galvin Engineering CliniMix Thermostatic Progressive Mixing Valves is guaranteed free from manufacturing faults for a period of 12 months, subject to the condition outlines below;

GALVIN ENGINEERING PRODUCT WARRANTY

Subject to the warranty conditions and exclusions set out below, Galvin Engineering products are warranted to be free from defects in materials and/or workmanship for a period of 12 months service life, and if found by Galvin Engineering to be so defective will be replaced as set out below. If the product is sold by a party other than Galvin Engineering, then it is sold by the seller as principal and the seller has no authority from Galvin Engineering to give any additional warranty on behalf of Galvin Engineering.

The benefits of this warranty are in addition to all other rights and remedies which the purchaser may have under the Trade Practices Act or similar laws of each State and Territory in Australia.

Warranty Conditions and Exclusions

Conditions:

1. The TMV must have been installed by a licensed plumber in accordance with the Galvin Engineering Installation Instructions and Application Guidelines supplied with the valve, in accordance with local Plumbing and Drainage Codes at the date of installation and all relevant statutory and local requirements in which the product is installed.
2. Where the product is installed outside the boundaries of a metropolitan area as defined by Galvin Engineering, the cost of transport insurance and travelling shall be the purchaser's responsibility.
3. Where the valve comprises part of a hot water system, installation of that system must be in accordance with its manufacturer's recommendation, the Code and all relevant statutory and local State or Territory requirements.
4. The valve must be returned to Galvin Engineering together with a fully and correctly completed Galvin Engineering Warranty Claim Form.
5. Where the valve is replaced under warranty the replacement valve carries a new warranty as detailed herein.

Exclusions:

Replacement work will be carried out as set out in the Galvin Engineering Warranty above, but the following exclusions may cause the warranty to become void, and may incur a service charge including cost of parts where:

1. Damage has been caused by accident, Acts of God, misuse, incorrect installation, incorrect installation of the water supply system of which the product forms a part or attempts to disassemble the valve.
2. It is found that there is nothing wrong with the product
3. The failure of the valve is due in part or in whole to faulty manufacture/installation of the hot water supply system of which the product forms part.
4. The valve has failed directly or indirectly as a result of excessive water pressure or temperature outside the Supply Pressure Requirements, or corrosive environment.
5. The valve has failed due to foreign matter either from installation or the water supply.
6. The failure of the valve is due to scale formation in the waterways of the valve.
7. The failure of the valve is due in part, or in whole, to installation not in conformance with the requirements of the Code.
8. Galvin Engineering reserves the right to change its specifications without prior notice and will not accept liability for any claim arising from such change.
9. Subject to any statutory provisions to the contrary, claims for damage to furniture, carpets, walls, foundations or any other consequential loss either directly or indirectly due to leakage from the valve are also excluded from warranty cover.

Galvin Engineering Thermostatic Mixing Valve or Tempering Valve Commissioning Report and/or Maintenance Report

Note:

1. Please use a separate form for each valve.
2. The original copy of the report is to be given to the owner/occupier and retained on site for a minimum of 7 years.

Cross off appropriate box

Thermostatic Mixing Valve Tempering Valve

Commissioning Report Maintenance Report

Name of Establishment: _____

Address of Establishment: _____

Phone Number: _____ Date: _____ Work Order #: _____

Contact Person: _____ Make & Model of Hot Water System: _____

Temperature of Hot Water to the Valve: _____ Temperature of Cold Water to the Valve: _____

Hot Water Pressure: _____ kPa Cold Water Pressure: _____ kPa

Make of Mixing Valve: _____ Model No: _____ Size: _____

Valve Location/Building: _____

Valve Identification No: _____

Total No of Valves on the Site/Building: _____

No of Outlets Serviced by this Valve: Baths () Basins () Showers ()

Other Outlets - Details _____

Valves Installed to the requirements of:

The Valves manufacturers requirements	Yes	No
The specifications and drawings for the project	Yes	No
The Local Water Supply or Authority	Yes	No

If No, give details and actions taken:

Galvin Engineering Thermostatic Mixing Valve or Tempering Valve Commissioning Report and/or Maintenance Report

Test Results

Valve considered satisfactory for use: Yes No

If No, state the reason and action taken:

Commissioning Work

It is hereby certified that all the commissioning work has been carried out by the undersigned in accordance with the requirements of the Codes of Practice indicated prior.

Date of Valve Commissioned: _____

Name of Licensed Plumber: _____ License/Cert No: _____

License Plumbers Signature: _____

Telephone No. _____

Owner/occupiers signature: _____ Date: _____

Date of Initial Service Due: _____

Galvin Engineering Thermostatic Mixing Valve or Tempering Valve Commissioning Report

Valve Location/Building : _____

Room or Area: _____

Work Order No.: _____

Warm Water Outlet Fixture No.	*Name/Type/Size and location of Outlet Fixture (Bath, Shower, Basin, Other)	Flow rate of Design Water (LPS)		Temp of Warm Water (C)	
		One Outlet in Use	**All Req'd Outlets in Use	One Outlet in Use	**All Req'd Outlets in Use
1.					
2.					
3.					
4.					
5.					
6.					
7.					
8.					
9.					
10.					
11.					

*Give details of brand and model designation.

** Commensurate with the design flow rate for the mixing valve.

Note: An accurate digital thermometer is necessary for the temperature measurements

Prescribed temperature range for warm water _____ C to _____ C

Thermal shutdown at both minimum and maximum design flow rates

(Passed/Failed) Yes No Name of Plumber: _____

License/Cert No. _____

Licensee's Signature: _____ Date: _____ Telephone Number: _____

Galvin Engineering Thermostatic Mixing Valve or Tempering Valve Commissioning/Maintenance Report

The following information is to be provided by the site manager/owner/occupier.

Valve size and installation recommended by : _____

Valves supplied by: _____

Date of Installation: _____ Drawing No. _____

Service Manual on Site: Yes No

Commissioning Tests for new installation or valve replacement. Yes

This set of testing procedures and report received and witnessed by (Print Name): _____

Temperature setting at completion of commissioning _____ C

Position: _____ Signature: _____ Date: _____

Maintenance Tests. Yes

Date of Previous Service: _____

Previous Service carried out by: _____

Reason for Maintenance Tests: _____

This Test and report Witnessed by: _____

The valve has been operating/performing satisfactorily for the previous 12 months: Yes No

Comment on monthly Temperature Tests carried out by the owner: _____

Temperature setting at time of completion: _____ C

Current Report received and witnessed by:

Name: _____

Position: _____

Signature: _____ Date: _____